

SPORTS 250 SCOOTER OWNER'S MANUAL OPERATOR'S MANUAL

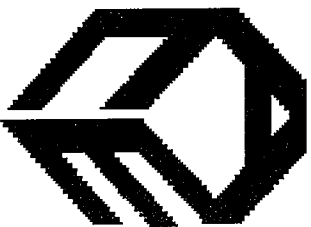

A.C.E.
SPORTS
acesportsonline.com

Read before operating the vehicle. Always wear a helmet and practice safe operating habits. Always obey traffic laws & posted signs for your safety.

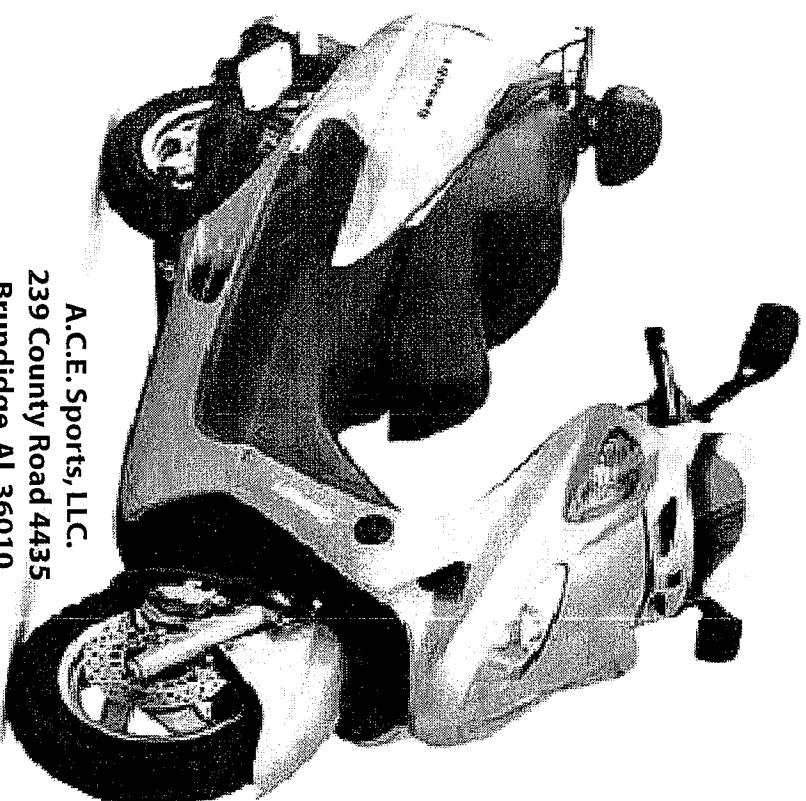

A.C.E. Sports, LLC.
239 County Road 4435
Brundidge, AL 36010
www.acesportsonline.com

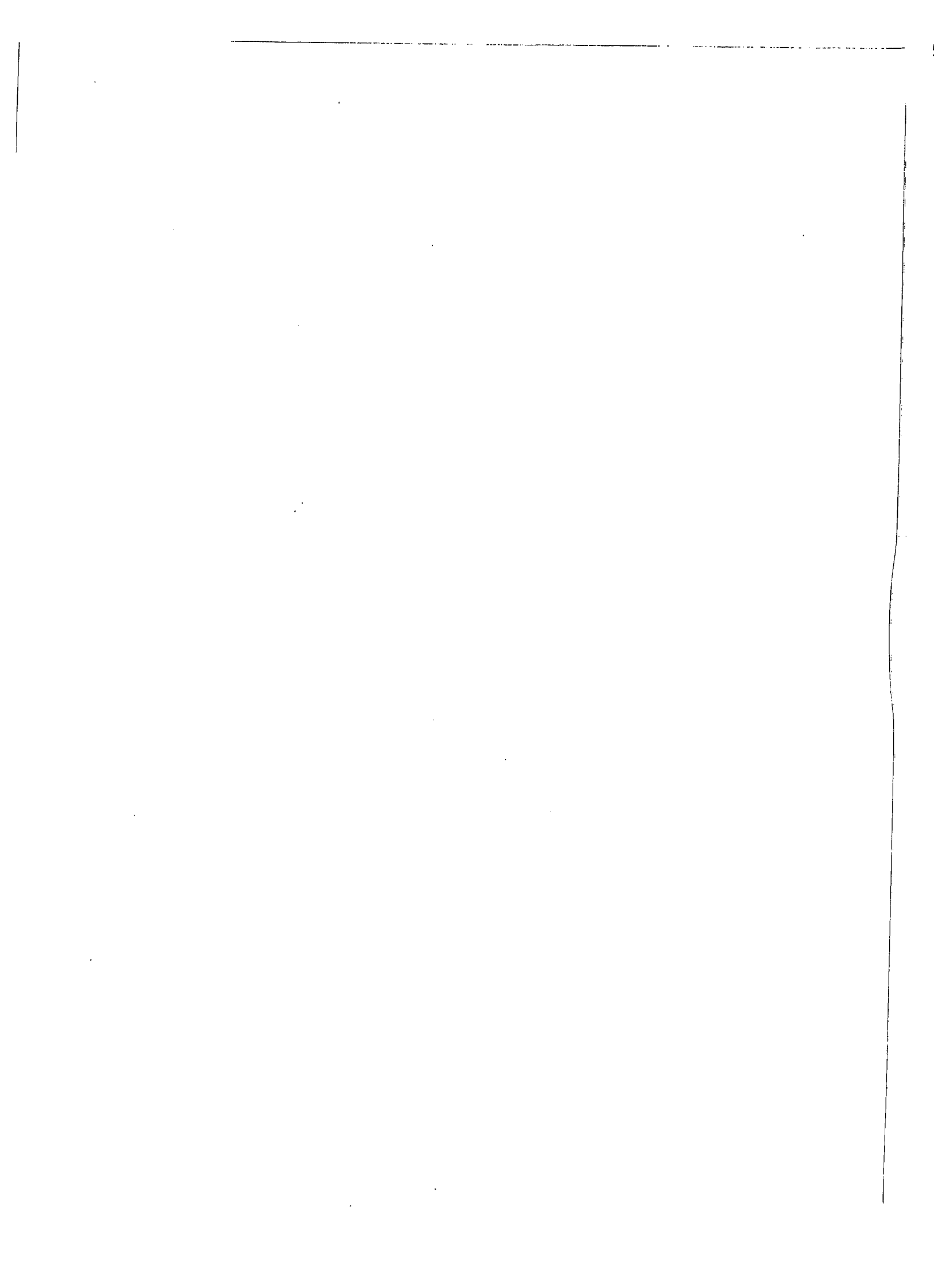



Thank you for your electing the motorcycle.

The motorcycle is consisted of excellent parts and components, with the advantage of large power, high speed, economic fuel-consume, low noise, advanced structure, beautiful outer-looking, elegance and air, safety driving and comfortable. It is very good in quality and cheap in price.

The book contains the matters of right using and maintaining, which make use full of you. If you find any exceptional things, please do not hesitate to contact with our service, which supply the service to you freely. If the parts will advanced, the content in book will different from the actual type without notice.

In order to protect to driving safely, please read the book carefully.

Hope you have a good driving time.

For advance, the picture and the actual type will be different from the content in book, we are very pleased that you can understand.

Contents

1. Regulations of safe driving	1	Correctly driving	21
Way of driving	2	Way of parking	21
Loading	3	5. Inspecting before driving	22
2. Locations of parts	4	Inspecting and supplying gasoline	23
3. Handling of parts	6	Inspect braking	24
Meters	6	Inspect braking light	25
Indicators	6	Inspect turn signal	25
Main switch	7	Inspect tire	26
Starting button switch comp head light	8	Inspect air cleaner	28
Changing switch, head light button comp horn	9	Replace fuel	28
Switch comp turn signal	10	Replace gear oil	29
Key, helmet luggage box	11	Inspect spark plug	30
Key comp steering handle	12	Term maintenance program and schedule	31
Front luggage box	13	Clean out the battery	32
Engine starting system	14	Replace the fuse	33
Electric starting	14	Cleaning way of air cleaner	34
Kick starting	15	Adjusting the carburetor and the choke	35
Water temperature indicator		6. Specification table	36
4. Natural way of driving		7. Electric circuit drawing	38

1. SAFE DRIVING

Clothes:

Safe driving main point is natural and relaxing mood and wearing comfortable dress.
Pay attention to driving with obeying ruler of traffic, don't worry and relax the mood.

CAUTION:

- The drivers don't wear loose or longed clothes, avoid to happen damage.
- The skin of body don't touch with the exhaust pipe after flameout the motorcycle within 10 minutes, for the temperature of it is very high during the driving.

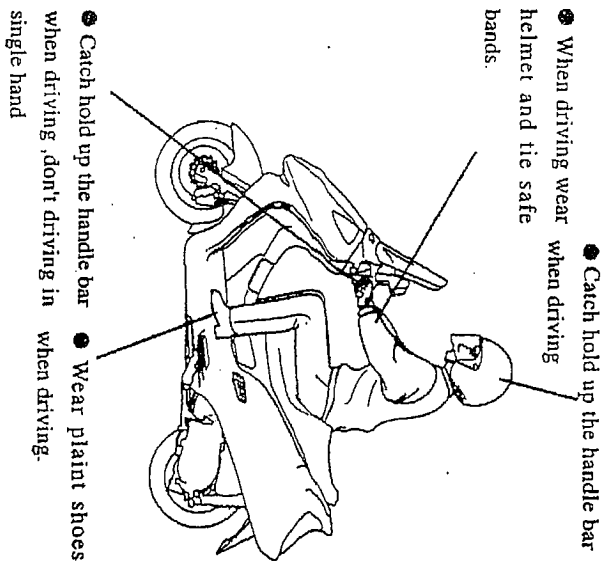

WAY OF DRIVING

- Keep your only natural posture to actively driving the motorcycle.

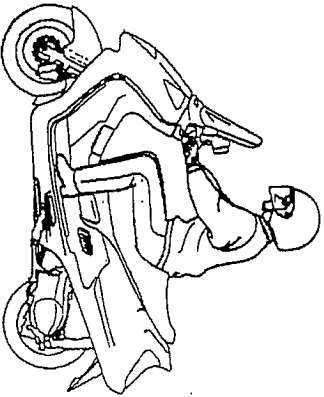

- The position effect on the rider's safe, please seat at the center of double seat, if driver seat at the end of double seat and make front wheel reduce weight and the handle bar will swing in a word, this happen to damage.

- When driving at the swerve, please keep the body to inner side, if else happen to damage.

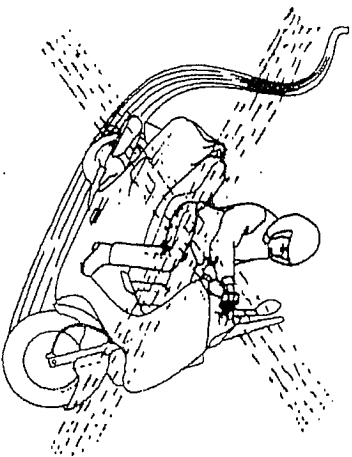

- Please pay attention to driving on the no-smooth road.

Loading

- The handle bar can feel the change of weight between the loading and no-loading. So please driving caution. When the loading overtaking, the handle bar shake easily, please avoid overtaking driving.

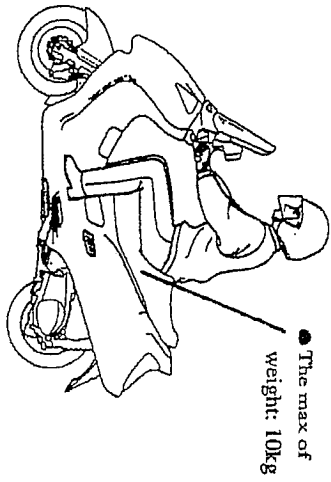

NOTE:

- Don't place the clothe under the seat (outer luggage), if else ,make the fuel system choked and the engine ill.
- Don't place the clothe between the outer cover of frame and the engine, if else happen to damage the engine.
- Don't replace the goods at the outer luggage which is pointed, avoid to damage the outer of frame body.

2.LOCATIONS OF PARTS:

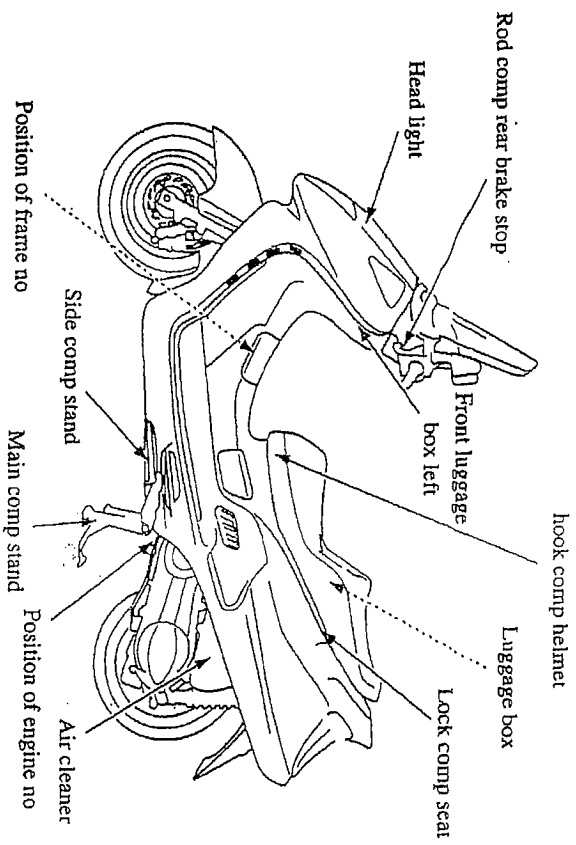

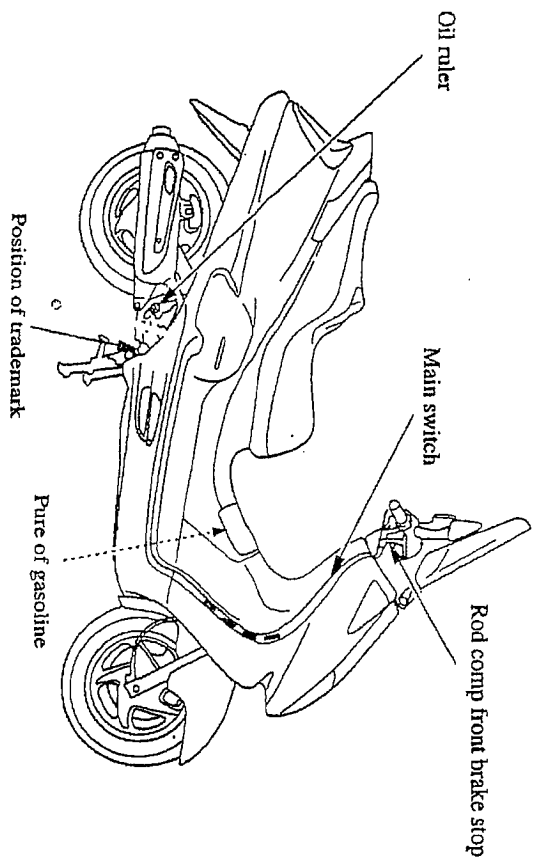

3. INSTRUCTIONS FOR THE MOTORCYCLE

■ Speedometer and indicator

(1) Mileage recorder

It displays the total distance covered by the vehicle (Km).

(2) Speed indicator

The standard of speed : Km/h

(3) Pilot of headlight

Pilot of headlight is switched and indicate the pilot light.

(4) Turn signal indicator

The signal is switched and the indicator is light.

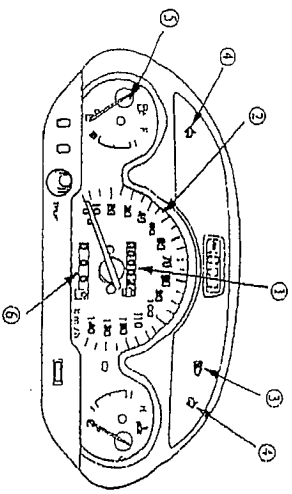

(5) Fuel meter

The fuel indicator shows the fuel capacity remaining in the fuel tank (when the main switch is ON, the meter indicates correctly. when the position of OFF, the meter is not correct.) When the needle is at the red zone, it indicated the fuel is 1.5L, and please supply the fuel 90# in time.

(6) Shortage distance meter

It is use for shortage distance and can indicate "0".

Main switch

OFF

- Electrical source is cut off and the engine stopped.
- The key can be taken down.

ON

- Electrical source is on and started.
- The key can not be taken down when driving.

LOCK

- The steering handle pipe is locked and avoid to theft.
- The key can be taken down.

NOTE:

- When parking the motorcycle, lock the turning bar and take down the key, avoid to theft the motorcycle.

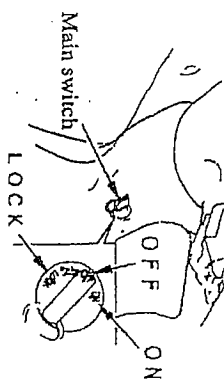

■ Starting button:

When use the electric starting, please draw the rod comp front brake stop, or step the pedal comp rear brake, until the electrical source is touched on .

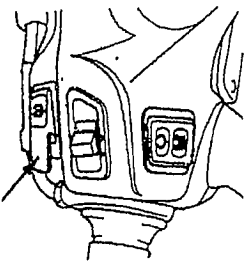

■ Switch comp headlight

■ Headlight OFF:

- Headlight, sidelights, speedometer light are shut off.
- Sidelights, speedometer light are switched on, (the engine don't start and the lights are shut off)
- Headlight, speedometer light are switched on (the engine don't start and the lights are shut off)

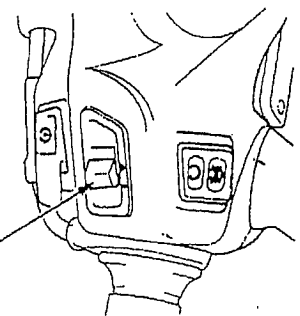
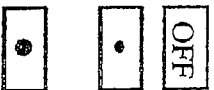

**HEAD LIGHT, CHANGE SWITCH
OVERTAKE SIGNAL SWITCH**

HI  When the pilot is switched, using the HI

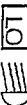
LO  When driving at the city and front vehicle, using the LO, avoid to effect on the sight of front.

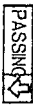
PASSING  Overtaking warning light at the position of LO, put down it and headlight is switched on, indicates front vehicle.

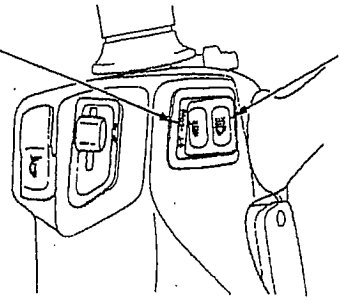

HORN BUTTON:

When the main switch is ON, put down the button of horn, and the horn tweets.

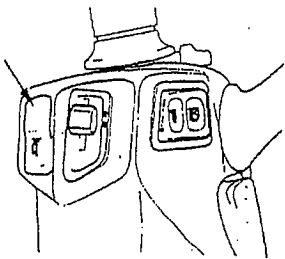

■ Switch comp turn signal:

When swerve or change roadway, please turn signal. When changing switch, the turn signal can spark or shut off.

- L : Using it at the turning left.
- R : Using it at the turning right.

NOTE:
● Please return the turn signal after using because it can't relax, if else effect on other people's safe.

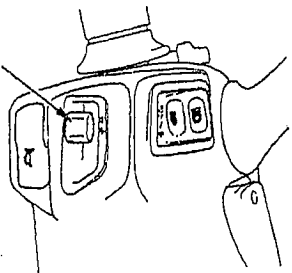

■ KEY OF HELMET

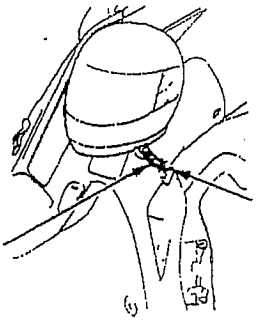

Way of using:

- (1) Open lock comp seat and put up the seat.
- (2) Make the key into hook.
- (3) Push down seat and the seat auto can be locked.

Way of taking down:

- The way of using is the same to above.

NOTE:

- When driving, don't make the key leave the helmet lock and avoid damage paint parts.

■ LUGGAGE BOX:

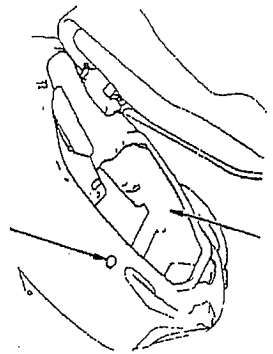

Luggage box lies under the seat.

Way of opening seat is the same as above.

NOTE:

- The max weight of loading: not exceed 10kg.
- Check the seat is locked.
- Don't place the low-heat-resistant goods, foods and combustible goods into the luggage box, because of the high temperature of engine.
- Don't place the expensive goods into the luggage.
- Don't make the water into the luggage box, when cleaning the motorcycle.

■ Key comp turning bar

Please lock the turning bar when parking in order to avoid theft.

<Way of lock>

Make the turning bar turn left full, and turn the main key to LOCK.

<Way of unchaining>

Turn the key to "OFF" and the key will auto unchain.

NOTE:

- Turn the turning bar lightly after locked it, and check it is locked.
- Don't turn the main to "LOCK", if else out of control of the turning bar and happen to damage.
- Don't parking the place where traffic is frequently.

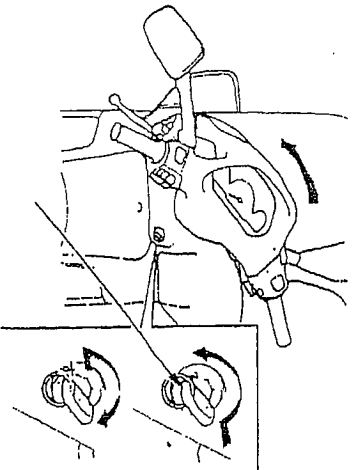

FRONT LUGGAGE BOX

Way of opening:

Insert the key and turn it right, the front luggage can push up.

Way of closing:

Insert the key and turn it right, close the cover of luggage box. And then turn left and take down.

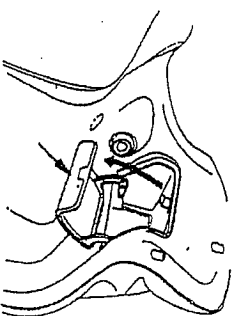
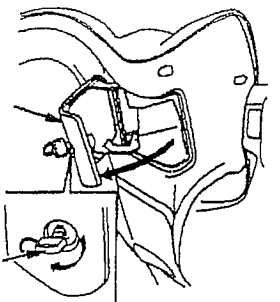

NOTE:

- The max weight of loading in front luggage box: not exceed 1.5Kg.
- Don't place the expensive goods into box.
- Please note the expensive goods placed, because water will into box when cleaning the motorcycle.

Way of starting for engine:

- (1) Check the gasoline, fuel and battery before starting.
- (2) Stand the main stand when starting engine, and make the rear wheel nearly room.
- (3) Turn the key of bank to "ON":

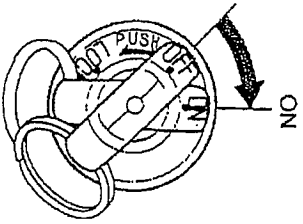

- (4) Adopt the electric/kick starting. If adopt electric starting, must catch hold of front brake bar or step rear brake pedal.

- (5) When driving in winter, turn the key of bank to "OFF", kick starting about 5 times and make into gasoline, then touché with the electric road, with accelerating and warm up the engine about 2-3 minutes. All are OK.

NOTE:

- Please using it according to above (5), when the gaso-line don't reach the standard of 90# or using it long time, and starting it again.
- When using the new motorcycle first, kick starting it and can longed the usagc life.

- (6) Because the motorcycle designed advanced electric starting valve, can start it with kick/electric starting.

<ELECTRIC STARTING>

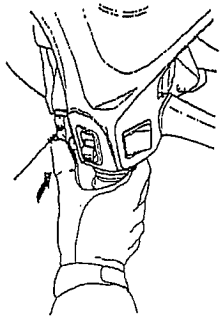

NOTE:
After starting the engine the hand leave the button and don't touch with it when driving; catch hold of the front brake bar or step the rear brake pedal, the braking light is switched, but pushing time is not exceed 3seconds, and the time share is about 10 seconds. The above times is not exceed 4times.

water temperature indicator
water temperature indicator is on the right of the speedometer showing the temperature of cooling water . when the needle is lower than the red line , it means the temperature is normal (80°C — 120°C), when the needle is higher than the red line, it means the temperature is too high. You should check the quantity of cooling water in the water tank, or check out if the engine is working normally.

▲ Note: in the hot condition, if engine is working on the idle speed for long time, it will be too. So it should be stopped to make it cool.

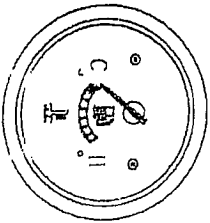

4.WAY OF NATURAL DRIVING

1 Spring the main stand firstly

- Push ahead and the main stand will auto spring.

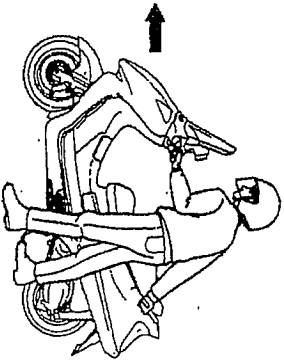

NOTE:
● Don't freely add oil and make the engine high speed before the engine don't driving.

- Ride the motorcycle from left side and seat well, the left foot touch with room and avoid to rave.

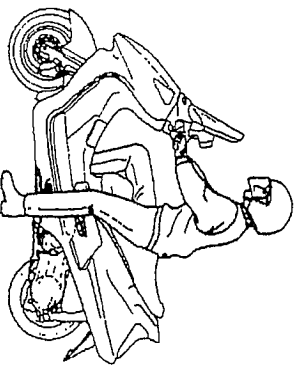

NOTE:
● Keep the front and rear brake the position of braking before driving.

2] Loose rod of rear brake

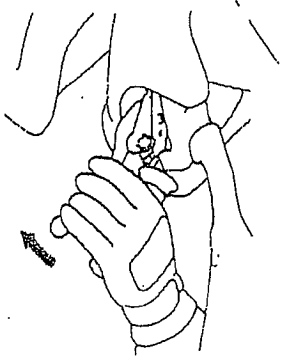

3] Turns the grip of throttle slowly and the motorcycle moves slowly.

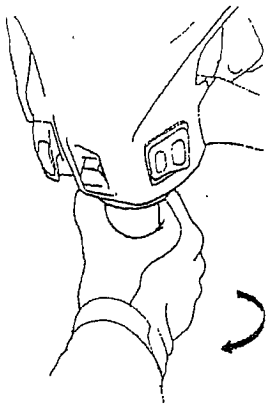

NOTE:

⚡ Don't add freely gasoline to the turning bar after loosening the rod of rear braking, avoid to happen dangerous.

NOTE:

⚡ Don't turn the grip of throttle quickly and avoid the motorcycle

4 Correctly driving

Before driving the motorcycle, please open turn signal and confirm the rear safe.

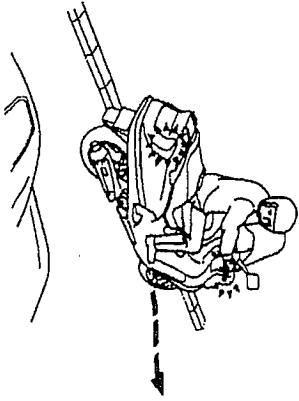

Adjusting of speed is controlled by the grip of throttle.

Return inner The speed will become faster, so please accelerate slowly.

The grip shall return to accelerate and the power become high when beginning to start or climbing.

Return origin position The speed become slowly.

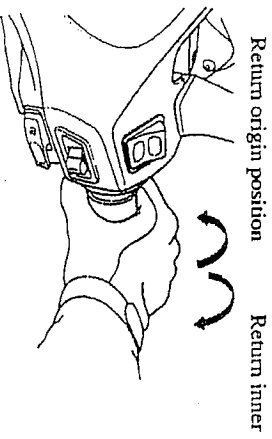

■ The first period of new motorcycle running will effect on the usage of engine.

● Please keep the speed less 60km/h in the first period of 1500km, details as followings:

Driving mileage	0 - 300	300 - 500	500 - 1000	1000 - 1500
Speed km/h	25 - 30	35 - 40	45 - 50	55 - 60

- Avoid accelerating quickly and overtaking loading.
- Replace the oil of crankcase and gear oil in the warm condition the period of meshing.
- Avoid to driving long time by the full throttle and notice to freely change speed, when the distance of driving are over 1500km.

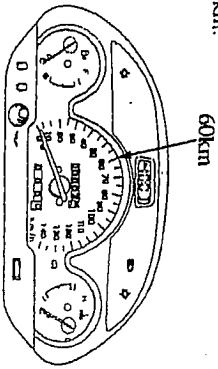

■ Using the front & rear braking stopping when parking.

- Parking the motorcycle after returning the grip of throttle to origin position.
- Start to parking slowly, and then step and draw urgently the vehicle.

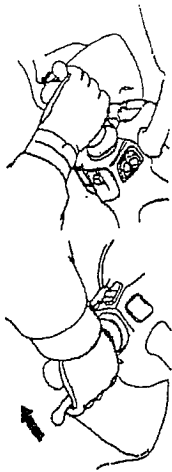

NOTE:

- Don't stop the motorcycle by the single wheel, if else, happen to accident.

Don't stop and swerve peremptorily

● Swerving and stopping peremptorily is one of cause of accidents and very danger.

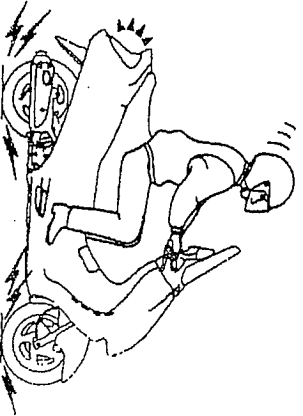

Notice driving the wet day.

● Please decelerate to drive because of longed the distance and the difference of road between the sung and wet days.
● Return the throttle grip to "OFF" and proper discontinuity braking when downgrade.

■ Way of parking:

1 Near the parking place:

- Open the turn signal ahead of time and notice the rear and side of vehicle and stop it slowly.
- Return the grip of throttle to origin position and brake the vehicle, at this time the rear braking light is switched and warn the rear vehicle.

NOTICE: If the vehicle inclines excessively which parking which make the idle speed instability.

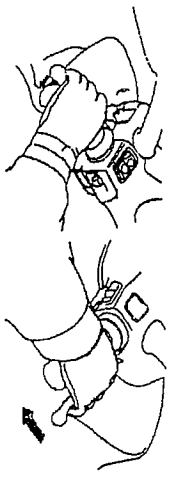

2 The vehicle complete stop

Return the turn signal to origin position and switch to "OFF".

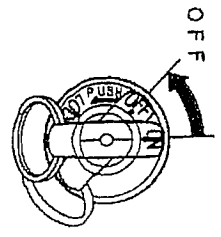

NOTICE:
● When driving if cut off main switch and take out key, the electric system don't work, and happen to accident easily. So please handle it when parking.

3 When parking

Stand the left side of motorcycle in the smooth land and support main stand of motorcycle.

- Support the main stand in the little traffic and smooth land, if else happen to accident easily.
- The left hand catches hold of handle bar and the right handle draws side rod under seat. The right feet step main stand and the right hand draw it rear.

4 Lock the handle bar and take out the key in order to avoid theft when parking.

(please reference the page 12)

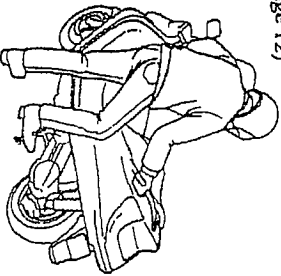

5. Inspection before driving

5.1 Inspection before driving

Please have a habit of checking vehicle before driving. Must check the vehicle before driving in order to avoid happening accident.

If you find the trouble of vehicle, please contact with the seller or service place.

5.2 CHECK AND SUPPLY OIL

1. Support the frame body and take out the ruler of oil to clean.
2. Straightly insert the ruler of oil.
3. Take out the ruler of oil and check the rest oil. If the level of oil reach at the under limit, please supply the oil until the upper limit.

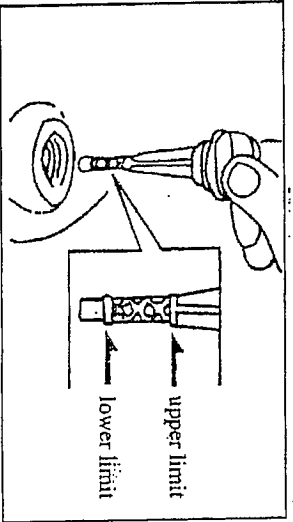

APPOINTED SPECIAL OIL

Four stroke special oil: SAE10w-30 (SIGMA)

NOTICE:

1. Don't use the counterfeit oil, if it else happen easily accident.
2. Please use and supply the oil according to state, in order to assure the safe and natural driving.

CHECK AND SUPPLY GASOLINE

- Supply the oil when the needle reach the red zone, at this time the rest gasoline is about 1.5L.
- Supply the gasoline of 90# in time.

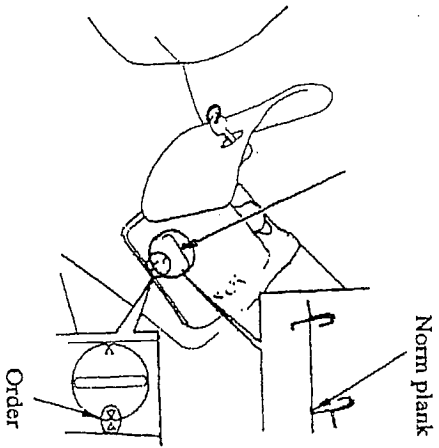

☑ CHECK BRAKING

《WINDAGE OF BRAKING ROD》

The braking rod must have proper windage. And it's active is work naturally.

Range of measuring windage : 1-2 cm

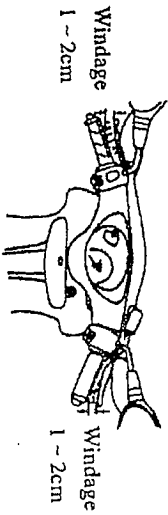

《CHECKING BRAKING OIL》

1. Place the handle bar correctly, check the braking oil in right fuel tank, and keep it the position between the upper and under limit.
2. Check the meshing of rubber when the braking reaches the under limit.
3. Please maintain it to the service place when the rubber worn but not exceed the stated ruler.
4. Recommend the braking oil: DOT3

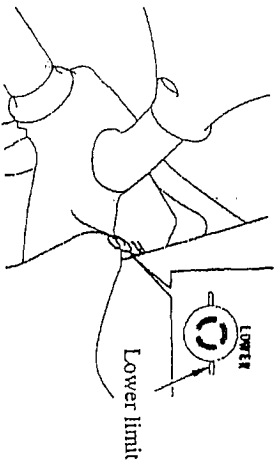

3 Inspection of braking light

- 1 Turn the main switch to "ON".
- 2 Brake the front & rear braking and confirm the light is switched.
- 3 Check the braking light is broken and untidy.

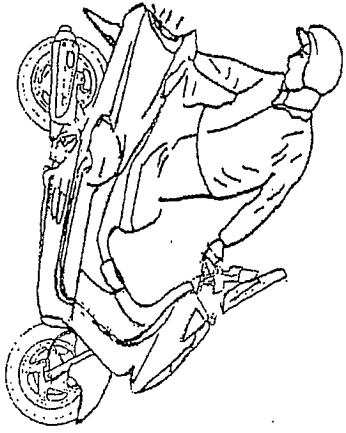

4 Inspection of turn signal

- 1 Turn the main switch to "ON".
- 2 Handle the switch of turn signal and confirm the front, rear, left and right turn signal, turn signal indicator are switched.

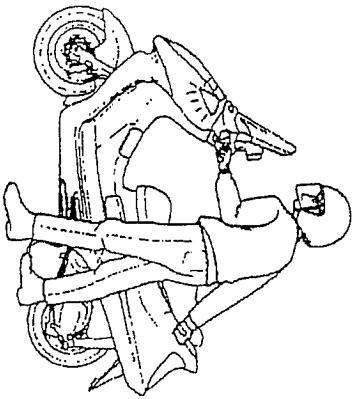

[6] Inspection of wheel

- Check the pressure of tire

Natural pressure
Front wheel tire:.....190Kpa
Rear wheel tire:.....221Kpa

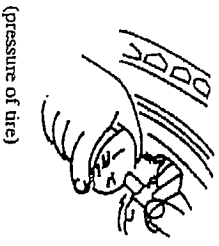

- Check and clean out metal and crush pieces in the tire trough.
- Please change into new tire, if the crush or the depth of trough reach the limit.

(Please reference the drawing)
(Metal, crush piece and other impurity)

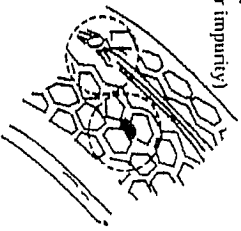

(Indication of meshing limit)



How to adding cooling liquid

Take the cover of radiator, add cooling liquid till full, start the engine. Then add speed times to make Sure the face of liquid is smooth . stop the engine and add the cooling liquid again to the intake. Fix up the Cover, and check the minor water tank.

Warning: forbidden to open the water tank cover when the engine is hot, if not will hurt person.

Checking the quantity of cooling liquid

- Check the water tank and pipe are water leak or not.
- Check the quantity is between the up limit ① or low limit ③ , if the water is not enough, open the cover ② , add to up limit.

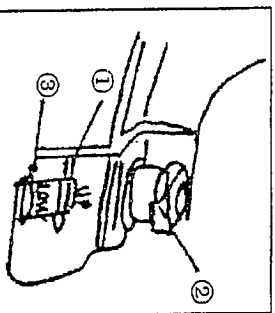

■ CHECK THE SPLINE COLLAR OF REAR TIRE AND FRONT & REAR HANGER SET

- When check the spline, support the vehicle by the center stand. Push the side of rear tire and look if the rear collar and the ring of rear fork loosen.
- Check carefully whether the location set of rear hanger system is stability.

■ CHECK AIR CLEANER

- The air cleaner is made in paper, and check and clean it every 2000km. After clean it, add equality a little oil.
 - Change into termly new air cleaner every 5000km.
- Way of changing reference the page 38.

NOTICE:

- Please replace and clean it under ways.
- Drive it in the wet days.
- Drive it in the dust roadway.

■ CHANGE OIL

Replace the oil firstly 300km, after every 1000km. Check the oil capacity every 500km and supply the oil in time until the limit. The capacity of oil:0.9L, and the oil capacity of normal changing: 0.75L.

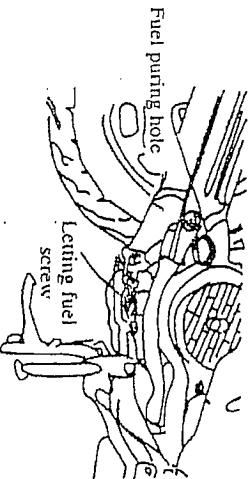

NOTE: Please replace the oil ahead of time driving the crush, short distance and cold zone place. When get down the screw of letting oil, clean the filter and fit it.

Change gear oil

(Term of changing)

Replace into the 10# or GY gear oil firstly 300km and after every half a year or 3000km.

(Way of changing)

1. Support the vehicle in the smooth land.
2. Get down the screw of oil.
3. If change oil the warm of engine, the rest oil will pour out gear box.
4. Clean the screw of letting oil and lock it.
5. Pure the oil into the gear box from the hole.
6. Lock the screw and avoid leakage.

CAPACITY OF GEAR OIL

- Full capacity: 0.11L

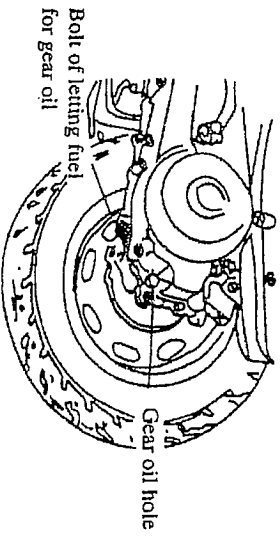

NOTICE:

- Please replace oil usually as followings:
- Driving the wet days usually.
- Driving long time (Long distance)
- Driving at the loading.

■ CHECK SPARK PLUG

The untidily of spark plug electrode and exceed windage effect on its work.

<Way of cleaning>

The best way is using cleaner of spark plug to clean.
If have not cleaner, please use the needle brush.

<ADJUSTING>

- Windage of side pole : 0.6-0.7 mm
(Reference drawing)

<Appointed spark plug >

G7HSA(NGK)
U22FS-U(ND)

NOTE: Don't use the spark plug which isn't appointed.

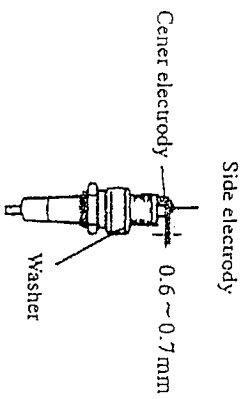

NOTICE:

- Notice not to scald body because of high temperature of engine after stopping it.
- Twist into the spark plug with hands and wrench.

TERMILY MAINTAIN PROJECT AND SCHEDULE:

Assure to driving safely, maintain the performance, longed the usage and reduce the pollute, please check and maintain it termly.

I: Checking, cleaning, lubricating, adjusting, or replacing A: adjustment C: cleaning R: Replacing T: Lock

ITEMS	DRIVING DISTANCE (km)													CHECKING BEFORE DRIVING	
	300	1000	2000	3000	4000	5000	6000	7000	8000	9000	10000	11000	12000		
Engine oil	R	R	R	R	R	R	R	R	R	R	R	R	R	R	I
Oil filter web	C		C		C		C		C		C		C		C
Gear oil	R		R		R		R		R		R		R		R
Spark plug		A			A		A		A		A		A		A
Valve of valve in(0, 12,out(0, 12 (cold system)		A			A		A		A		A		A		A
Cam chain		A			A		A		A		A		A		A
Carburetor			I				I				I				I
Air cleaner															
Electrolyte of battery		I	I	I	I	I	I	I	I	I	I	I	I	I	I
Fuel filter web															
Braking system		I	I	I	I	I	I	I	I	I	I	I	I	I	I
Drive belt					I				I				I		I
Parts screw and nut				T					T				T		T
Waste air deepness															

- The above items will change according to deferent from the kind of vehicle.
- Use it as compare with the schedule if overtake the mileages.
- Please clean and replace the air cleaner usually driving the dust area.

■ CHECK THE ELECTROLYTE OF BATTERY

□ The vehicle adopt no-supplying water or supplying electrolyte battery.

Don't need to check and supply the no-supplying water battery.

NOTICE:

- Don't get down the seal electrolyte battery.
- When don't use the vehicle, please get down the battery and put up the cold and good air place, because it automatic discharge and reduce the power.
- Don't use the vehicle long time, please get down the cathode.

The line of liquid keep the level between the upper and the under limit, when use the supplying electrolyte battery. And supply proper the distilled water sometimes and keep up the good air condition.

□ BATTERY HEAD

Firstly get down the three screws and battery cover when cleaning the battery head.

- Get down and clean the battery when the battery head is rotten.
- After cleaning it, please wipe a group of butter or Vaseline and fit it.

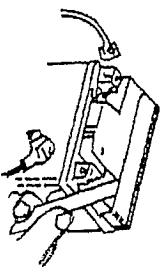

NOTICE:

- When getting down, shut off the electric source and get down the cathode. When fitting on, firstly fit on the positive pole.
- Lock the screw of battery head when it loosens.

Replace the fuse

Shut off the main switch and check whether the fuse is scaled or not

Replace the fuse according to the power appointed.

● Please find the clause-of scaling and replace it.

● Get down the three screw and open cover, the fuse lie in the fuse box side of battery.

● Open the fuse box and take out the fuse, draw the guide cable of the fuse.

The specification of fuse: 7A



Wire harness assy



Fuse clip



Insert
Fixing

- Change the electric goods (Ljgn, speedometer) according to the specification good parts appointed.
- If use the disqualification parts, the fuse is scaled easily and the loading of battery will lose it's balance.
- When cleaning the vehicle, avoid using water to clean.

NOTICE:

- When getting down, don't expand the ring too large.
- When fixing, please confirm whether the ring head loosens or not. It's loosening is the clause of troubles, and notice this.
- Don't use the exceed power of fuse, if else happen to damage.

Way of cleaning the air cleaner

Dust is the one of the cause of reducing the horsepower.

<Way of getting down>

1. Get down the five locked screws in the left rear cover and rear cover, and then get down the seven locked screws.
2. Get down the cover & air cleaner.
3. Get down the two located screw of air cleaner.
4. Replace the scar of air cleaner.

<Way of fixing>

- Operate it according to above contrary ways.

NOTICE:

- If the air cleaner is not complete fit, the dust will enter into cylinder and make the horsepower down and usage of engine.
- Don't soaked air cleaner when cleaning the vehicle, if else make the engine ill.

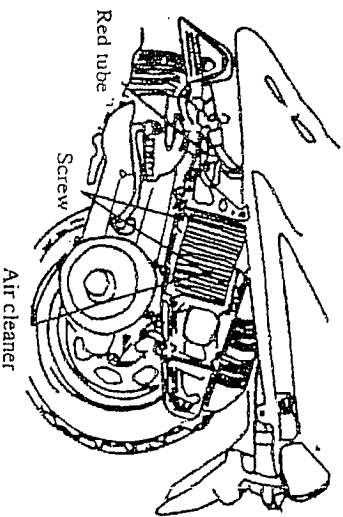
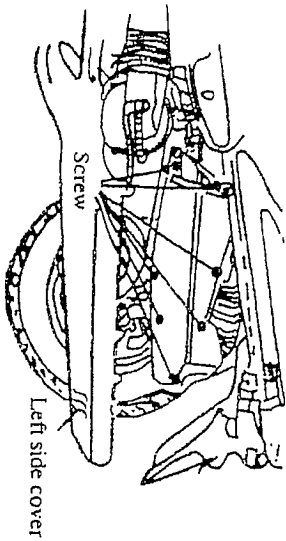

NOTE: Please let out the oil in red tube every driving 1000km.

■ ADJUST THE CARBURETOR AND CHOKE

Function of stability: Contrary can assure to the performance of the engine. The carburetor is adjusted the best condition in the manufacture and don't change the condition. Now you shall adjust the two projects as followings: adjusting of choke and idle speed.

(a) Adjusting of choke

1. Check whether the choke and throttle work well the conditions of full opening and closing for choke or not.
2. Check the free distance in the position of drawing turn bar, and the free distance: 2-6mm. If adjust the distance, please loosen nut (1) and adjustor (2).

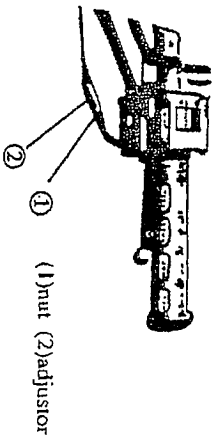

(b) Adjust the idle speed

1. Warm the engine many minutes and start it.
2. Twist the adjusting nut of oil, and slowly drop it about $3\frac{1}{8}$ circle. Lock it the max place and adjust lightly the limited screw until reach at the requirement of idle speed.

6. THE SPECIFICATION SCHEDULE:

Over size :length × width × high	2070 × 735 × 1410	The min consume	L/100KM	< 2.9	
Wheel base:	mm	1450	Braking distance	m	< 7(30km/h)
Dead mass	kg	130	Climb performance	(°)	> 10
Capacity of fuel tank	kg	140	Engine model		172MM
Oil capacity of crankcase	L	12	Style	Single cylinder/Water cooling/1-stroke	
Trademark of fuel	L	0.9	Stroke × bore		72×60
fuel shop sign		RQ-90	Capacity	ML	244
Trademark of lubricant		Four stoke especial oil SAE10W-30(SIGMA)	Compression ratio		10: 1
The max speed	km/h	> 85	The max power	kW/r/min	11 (7000)
			The max torque	Nm/r/min	17.6 (5500)

Start	Electric /kick start	The specific-	front tire	120/70-12
Ignition system	CDI	cation of tire	Rear tire	110/90-10
Spark plug	C7HSA(NGK) UJ22FS-U(ND)	Pressing of tire:	Front tire	196
			Rear tire	221
Lubricant system	Force lubricant	Electric system		
Clutch	Dry-auto acentric	Battery	12V7Ah	
Change speed system	Belt auto no-grade shift	Head light	12V35W/35W	
Decelerate ratio	1 time, 2.800 U time, 3.076	Tail light/ braking light	12V 8W/20W	
		Winker comp front left & right	12V 10W° 4	
		License light	12V 5W	
		Speedometer indicator	12V 1.7W° 3	
		Fuse	7A	
		Horn	12V 3A 105dB(A)	

7. CIRCUIT DIAGRAM

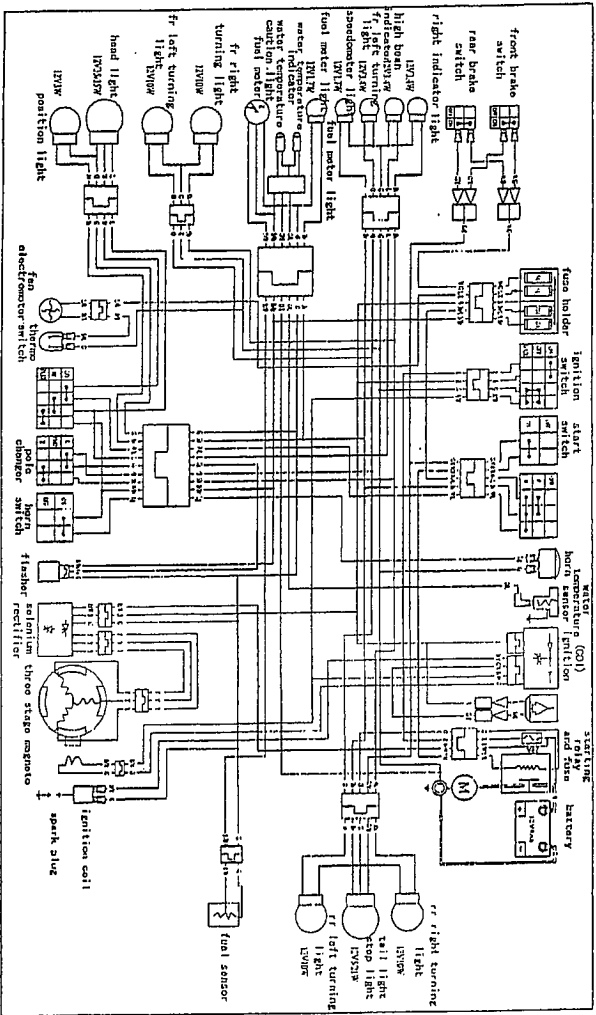

R=red B=black G=green L=black/white G/Y=green/yellow Y/R=yellow/red Br=brown Y=yellow L=blue W=white O=orange B/Y=black/white
 Y/R=black/white Y/W=yellow/white L=light green G=gray G/L=green/blue G/W=green/red Br=blue W/L=white/blue